

## 2.8 - LAYOUT

### Turntable D.1500

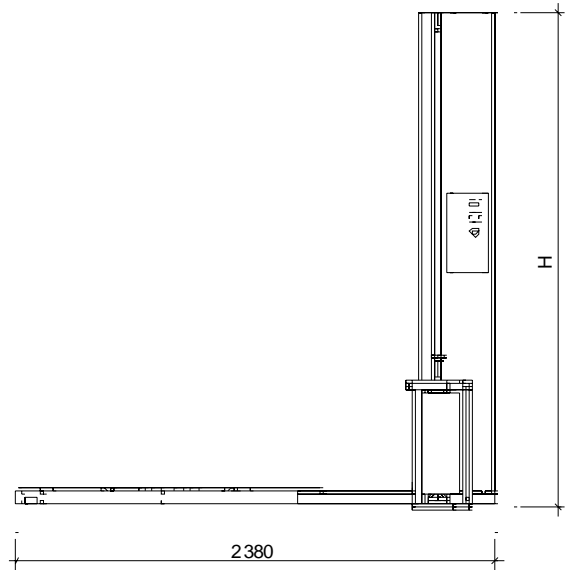

### Turntable D.1650

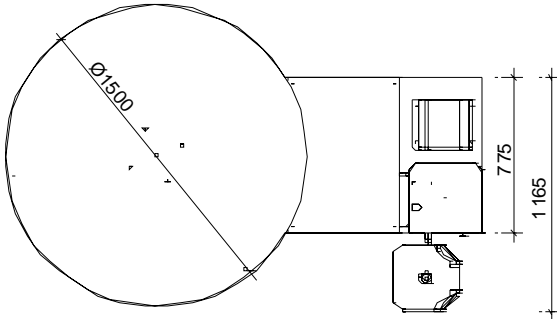
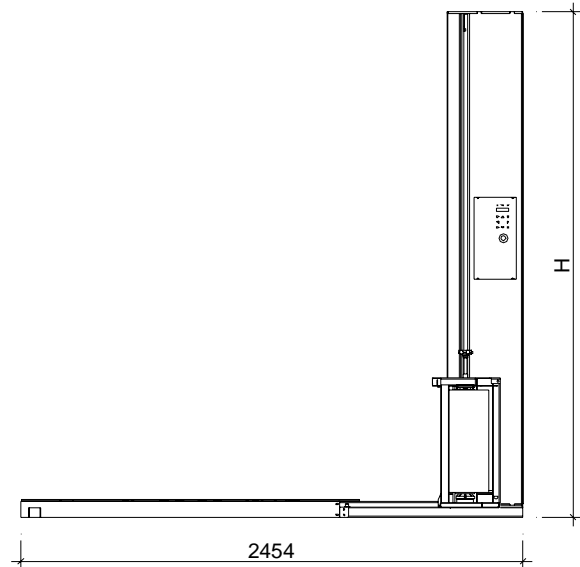
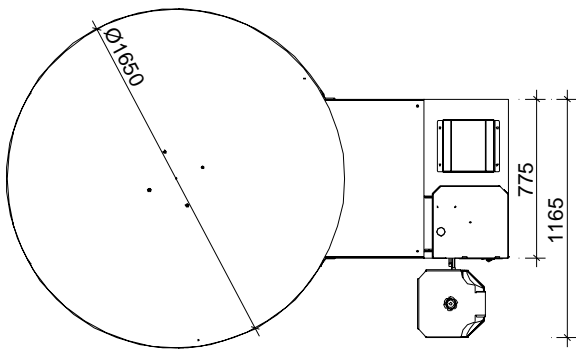

### Turntable D.1650 with motorized prestretch

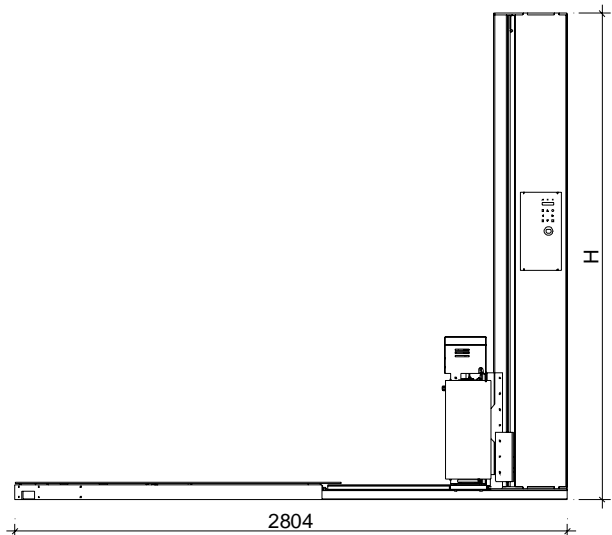
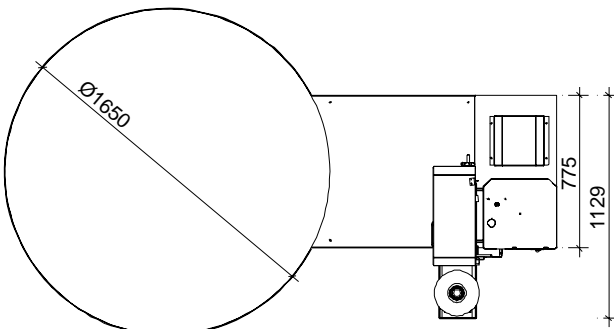

## Turntable D.1800

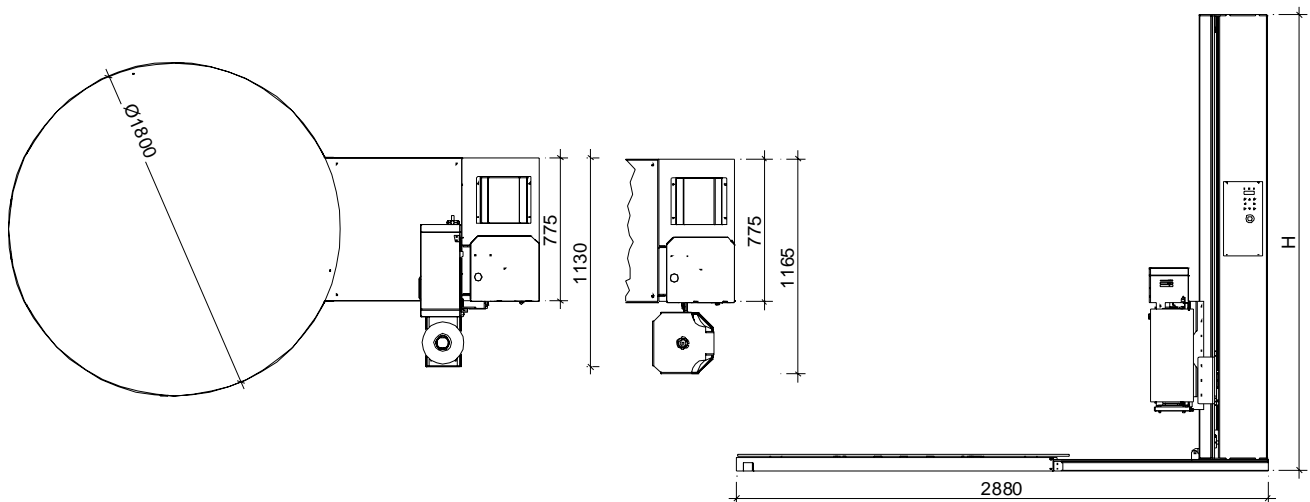

H = 2500 (STANDARD) - H = 2000 (OPTIONAL) - H = 3000 (OPTIONAL) - H = 3500 (OPTIONAL)

### 2.9 - TECHNICAL DATA

The following are the data and the technical characteristics for a correct installation.

POWER SUPPLY TENSION	230 Vac - 50 Hz
ABSORBED POWER	0,5 Kw
WEIGHT	REFER TO DATAT ON PLATE
DIMENSIONS	REFER TO PARAGRAPH 2.8
MAXIMUM LOAD WEIGHT	- 1200 Kg (STANDARD) - 2000 Kg (OPTIONAL) - OTHER CAPACITIES SUPPLIED UPON REQUEST.
ROTATION SPEED	12 RPM